

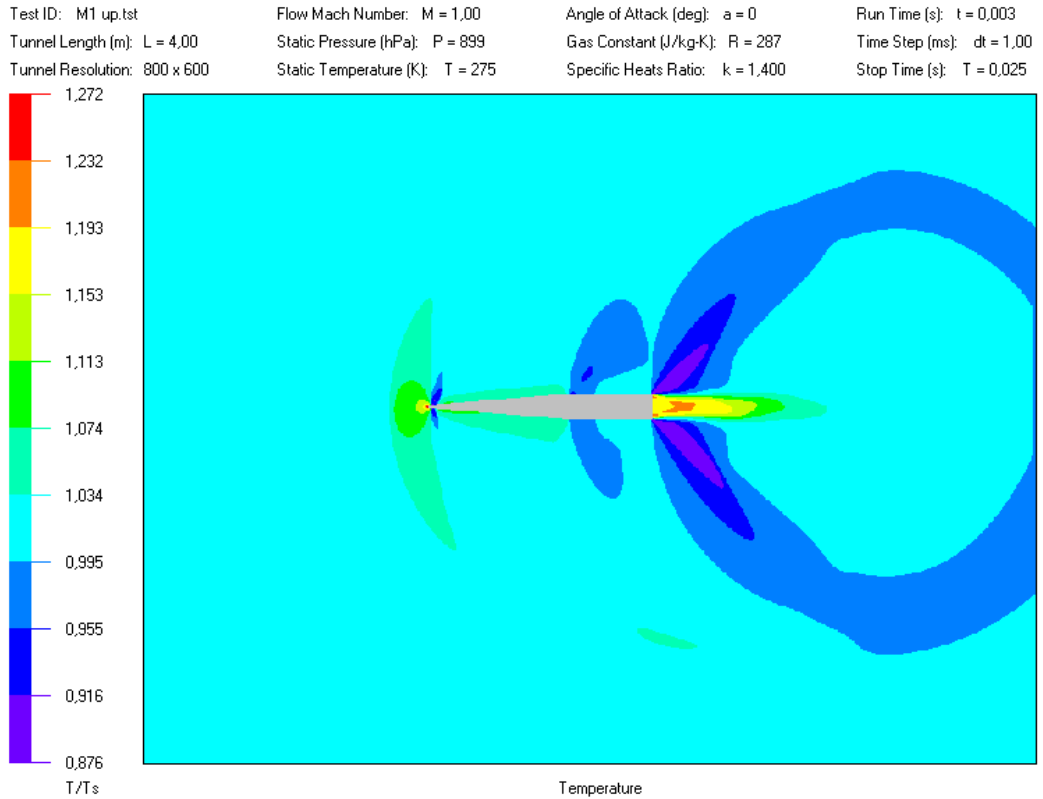

Heating of the SSTS NC in lower altitudes – partial study.

The purpose of this study is to illustrate heating of the SSTS nosecone during atmospheric flight. Because of limitation of the CFD computation software, I am unable to determine temperature profile in altitudes at lower pressure than 10hPa; this limit occurs in altitude over 30 km per Standard Atmospheric Model. I am also unable to determine exact surface temperature profile based on thermal decomposition properties of the surface layer of the NC outer skin. All surface temperatures are based on Micro-tunnel CFD; output data was not changed in any way. The NC shape has been simulated as true cone including round tip. Rear section of the NC has been extended by a part of the airframe to simulate shockwaves in transition area. All input data are based on SOAR047 RN file created 24th September 2005 and Hans Olaf Thoft Flight Prediction Data. The barometric pressure values and Mach No. are based on Standard Earth Atmosphere file. The launch point for purpose of this approximate study is expected to be at sea level. All temperature profiles are in steady state condition. All shapes are considered to be bodies of revolution.

1. Ascending Vehicle



M1, altitude about 1 km, attack angle 0 deg.

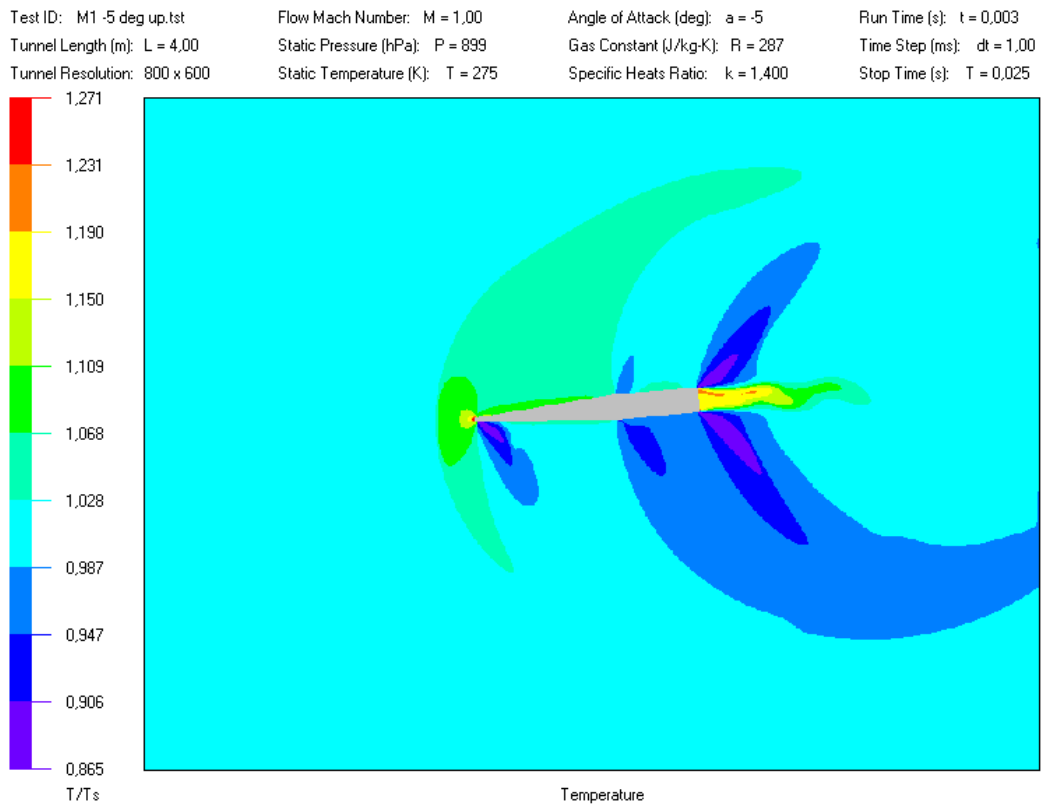

M1 at -5 deg. During possible wobbling, the temperature profile is changing. I am not expecting any wobbling at supersonic velocities; if there would be any, the aerodynamic loads would destroy the vehicle immediately.

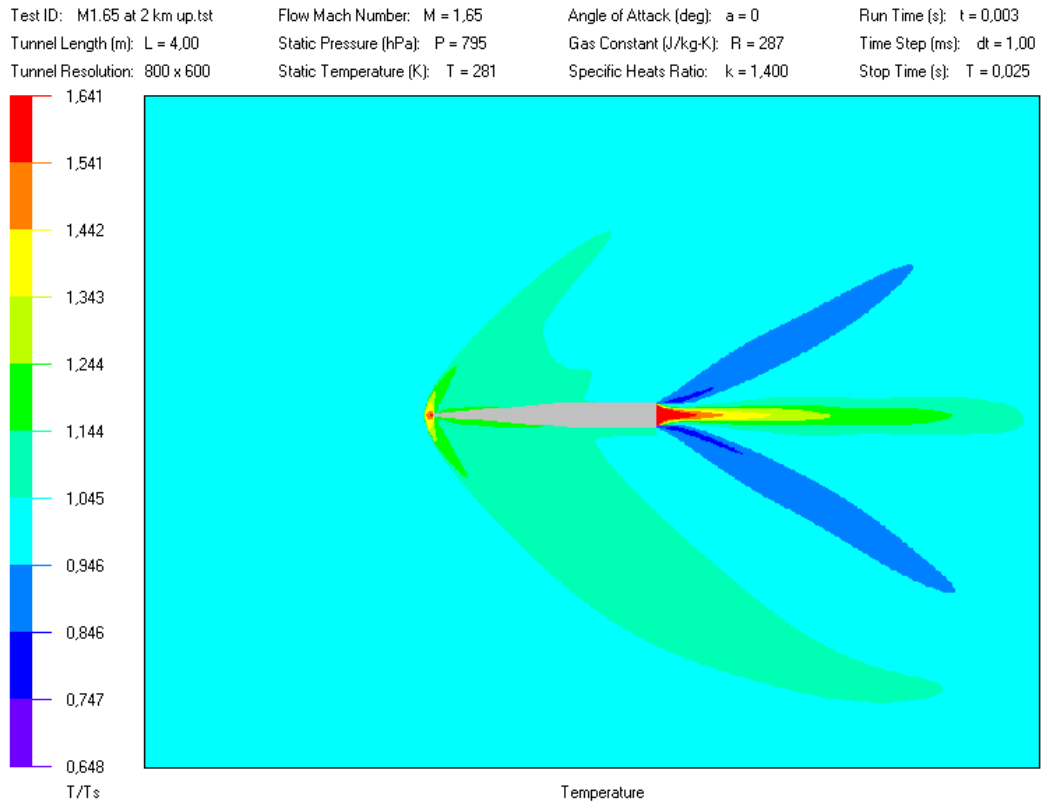

The M 1.65 maximum velocity is expected after burnout of the 1. stage; approximately 2 km above the launch site.

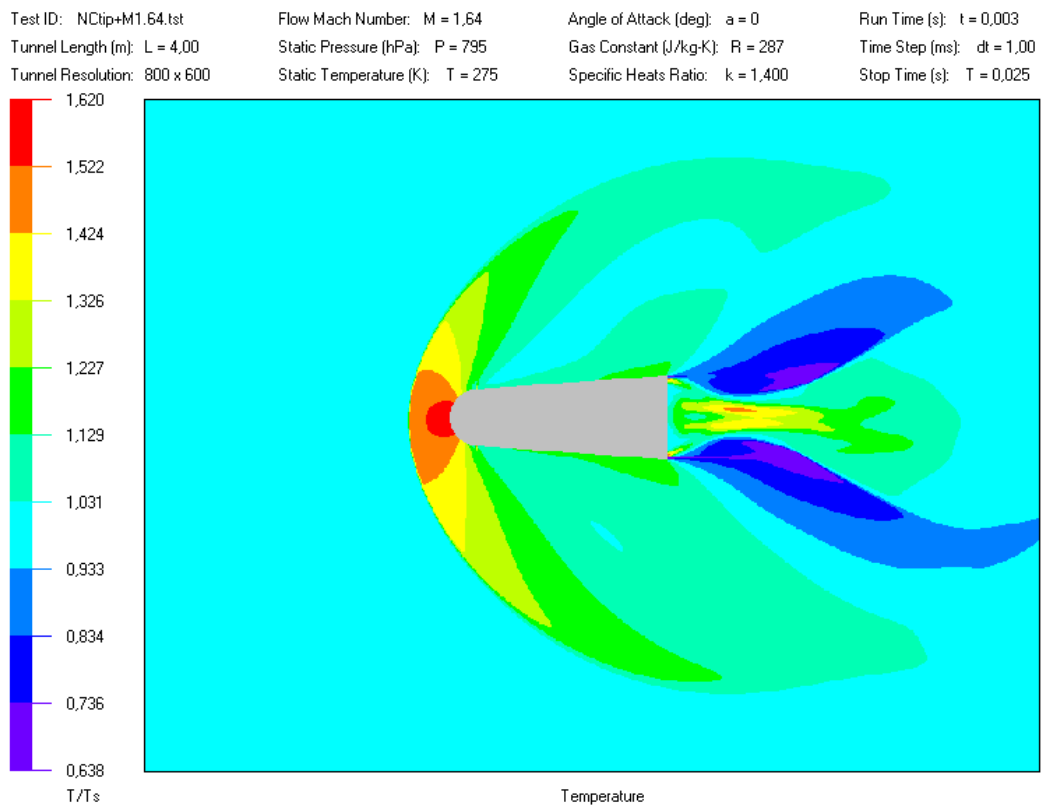

The NC tip at M1.64, attack angle 0 deg, detail.

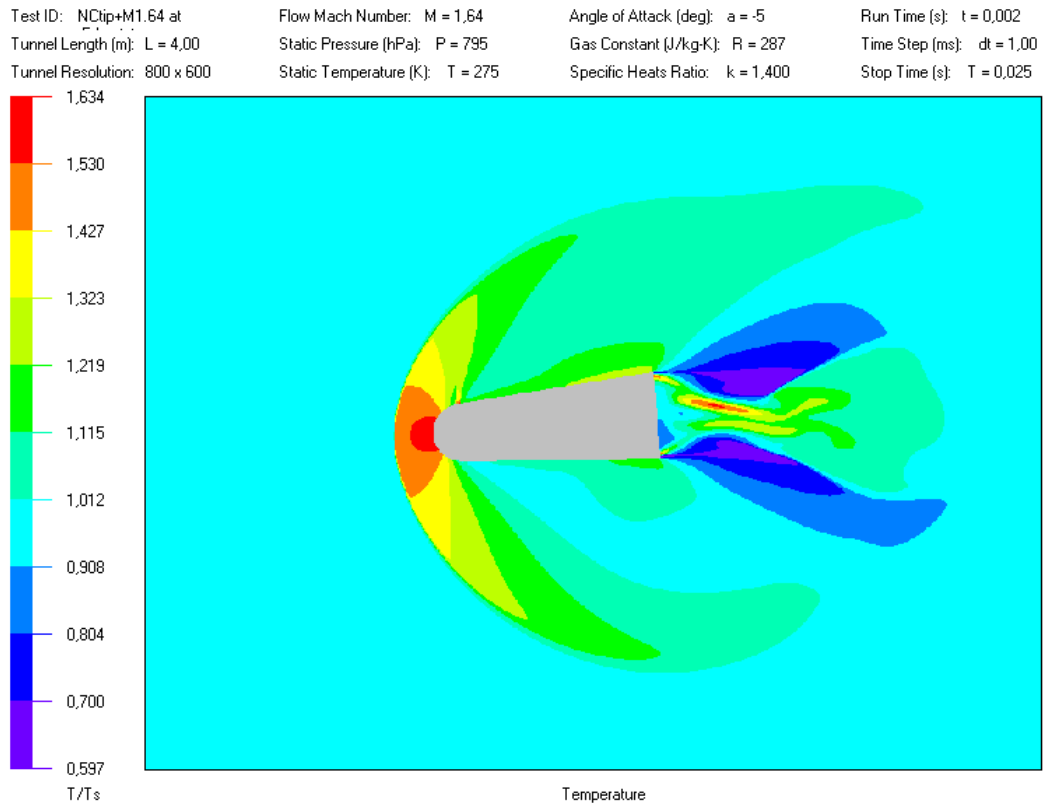

The NC tip at M1.64, attack angle -5deg . Temperature displacement in case of wobbling about 10deg of total amplitude.

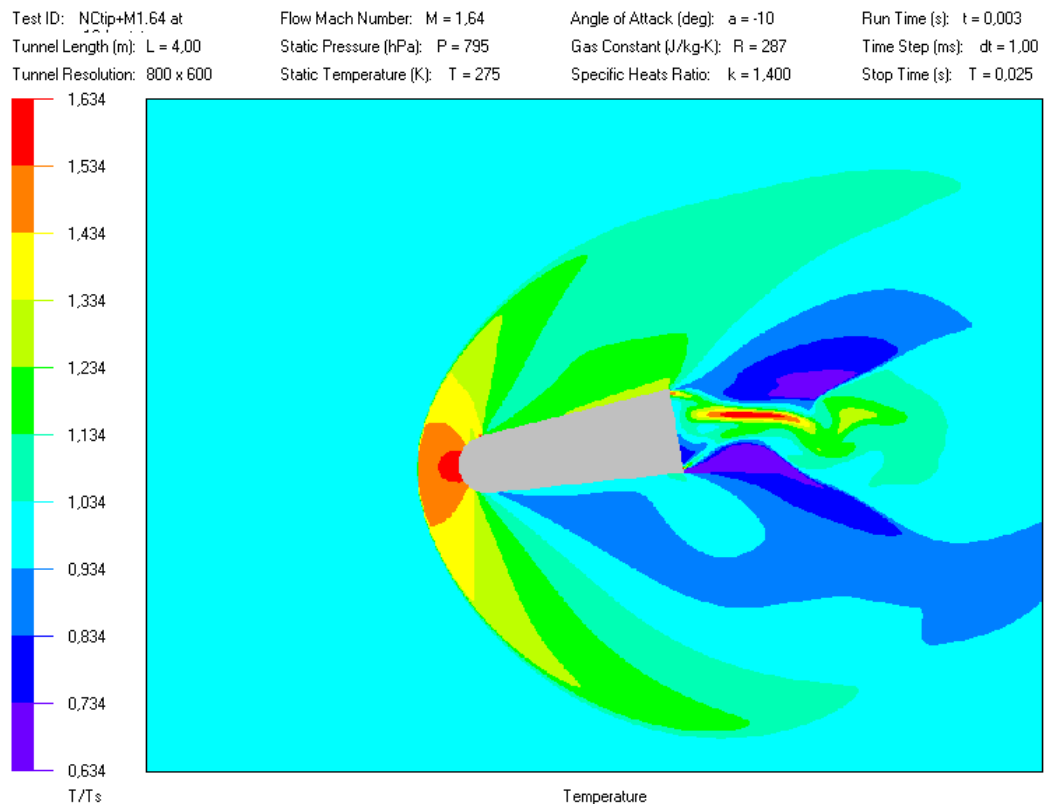

The NC tip at M1.64, attack angle -10deg . Temperature displacement in case of wobbling of 20deg total amplitude.

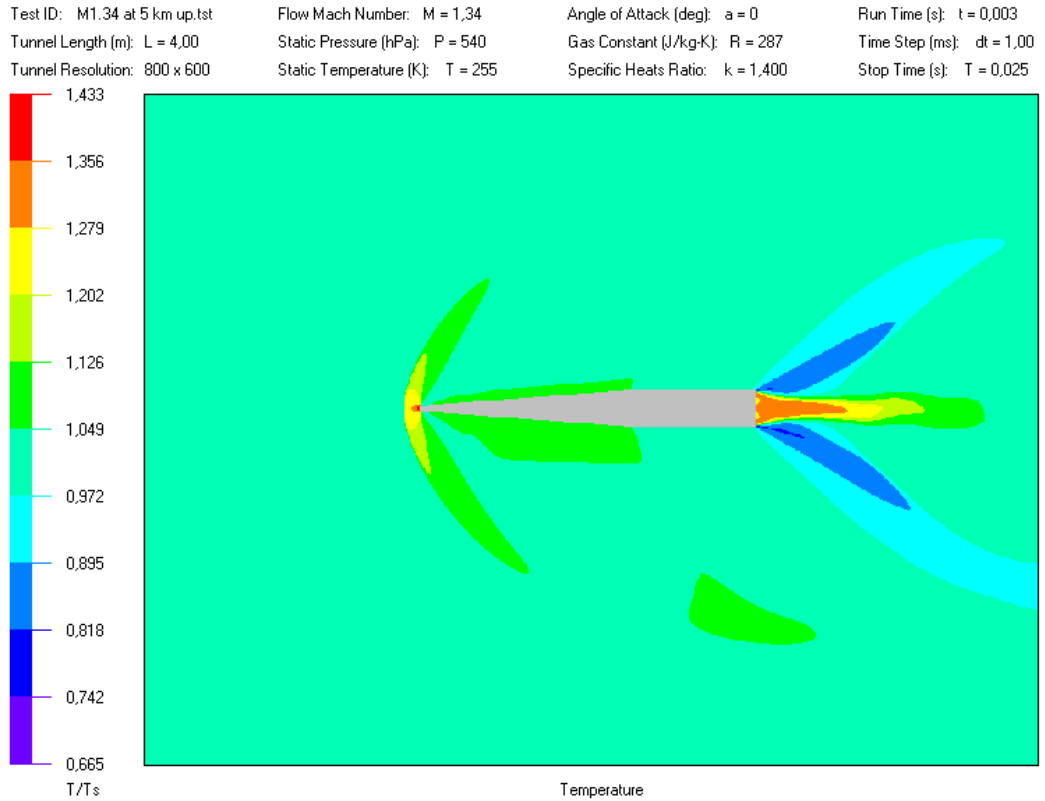

M1.34 at 5km, attack angle is 0deg. The velocity above the 2 km altitude is going to fall down; the first stage is expected to be completely burned out.

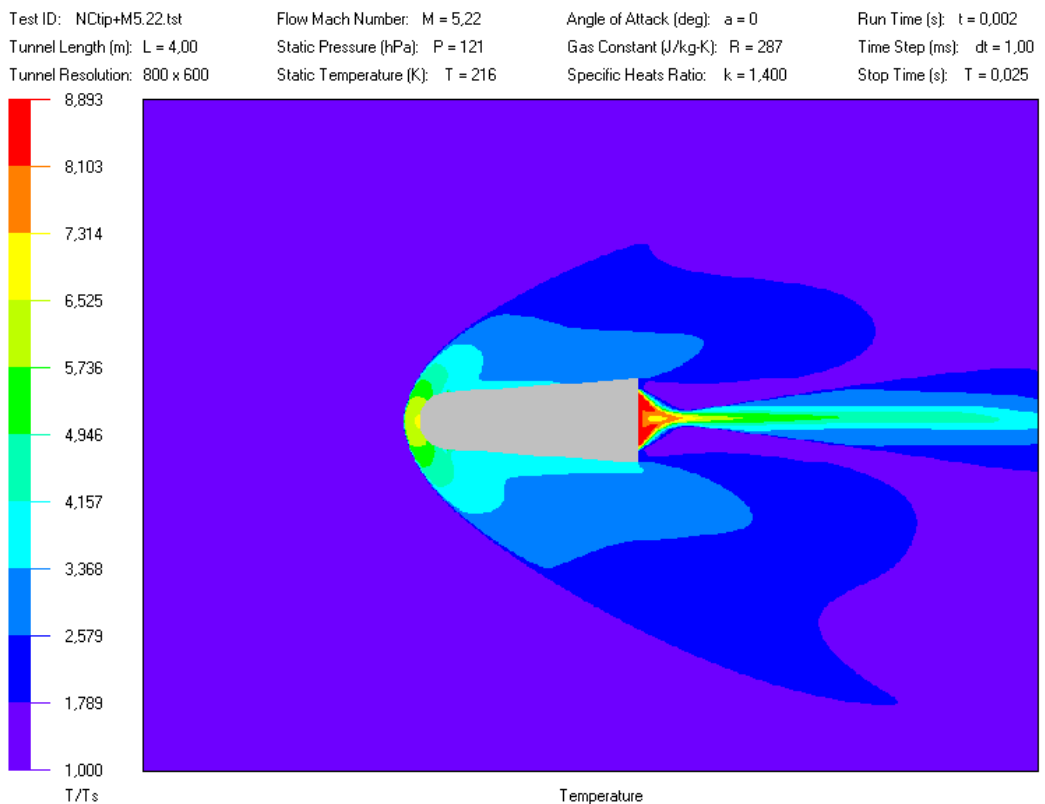

The next important point is reached at M5.22 when the velocity is at maximum; this occurs about 15 km above the launch site. Temperature of the NC tip reaches 1200 K. Cone temperature reaches approximately 800 K.

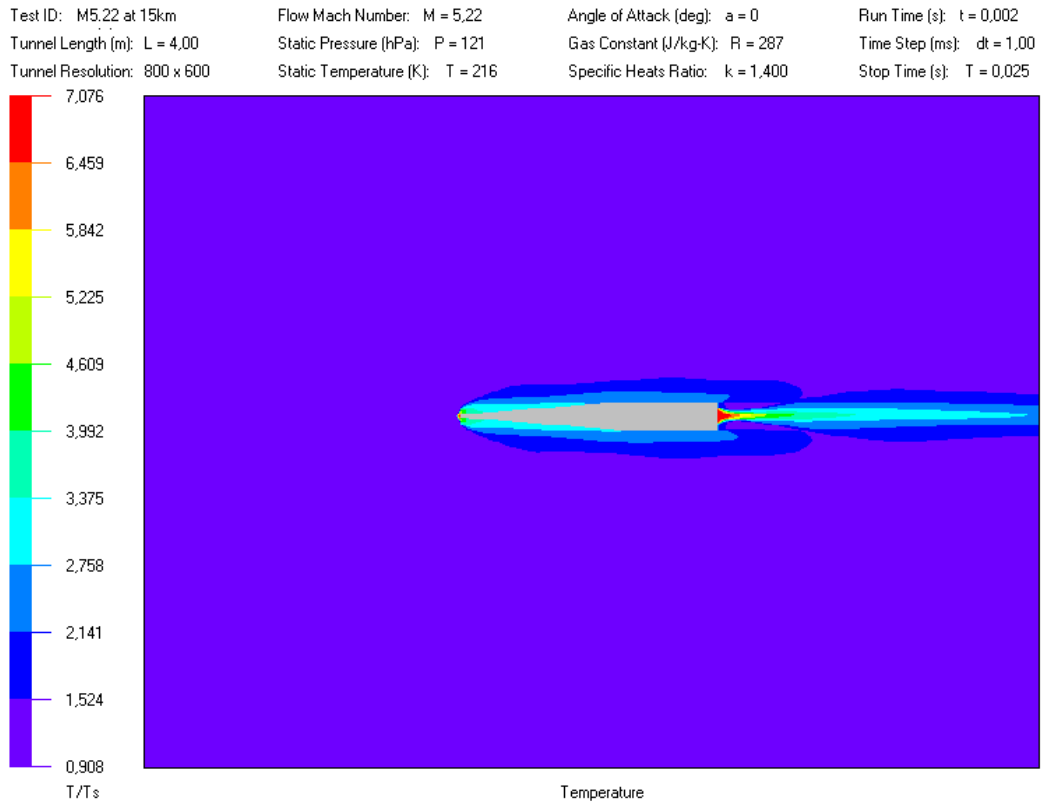

The surface temperature at M5.22 in 15km. Surface cone temperature is about 650 K.

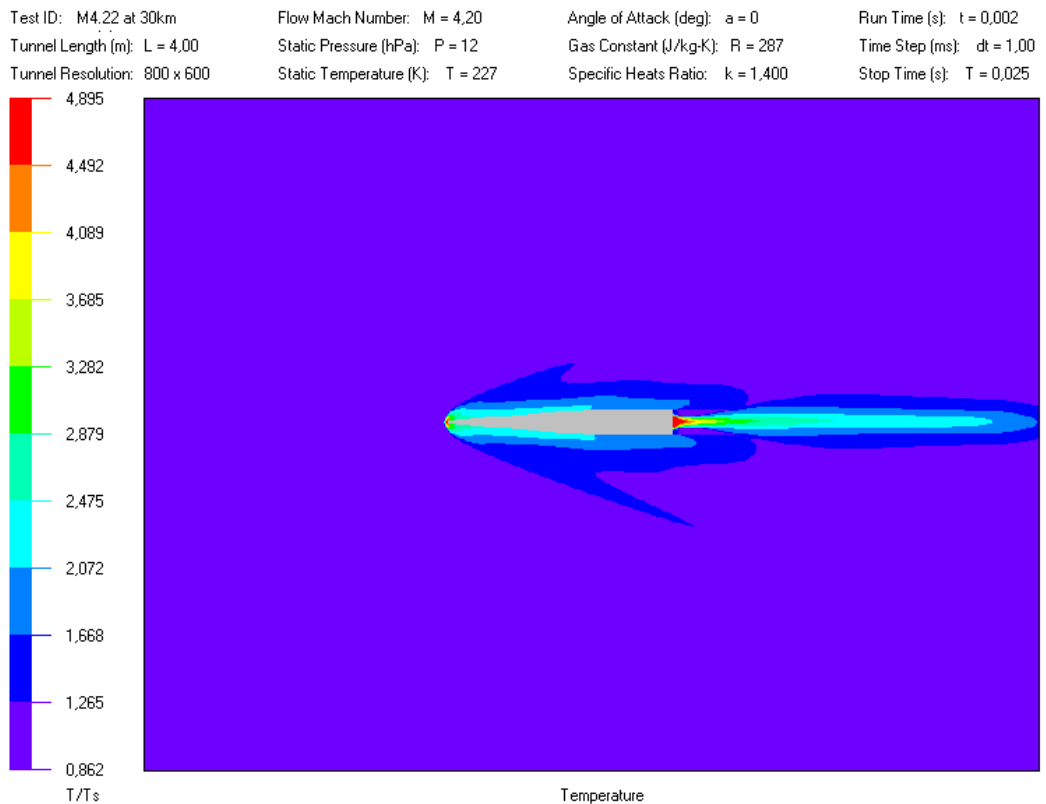

Altitude 30 km, velocity is approx M4.2. At this time, the temperature of the front section exceeds 600K; rear section approximately 500K.

2. Descending vehicle.

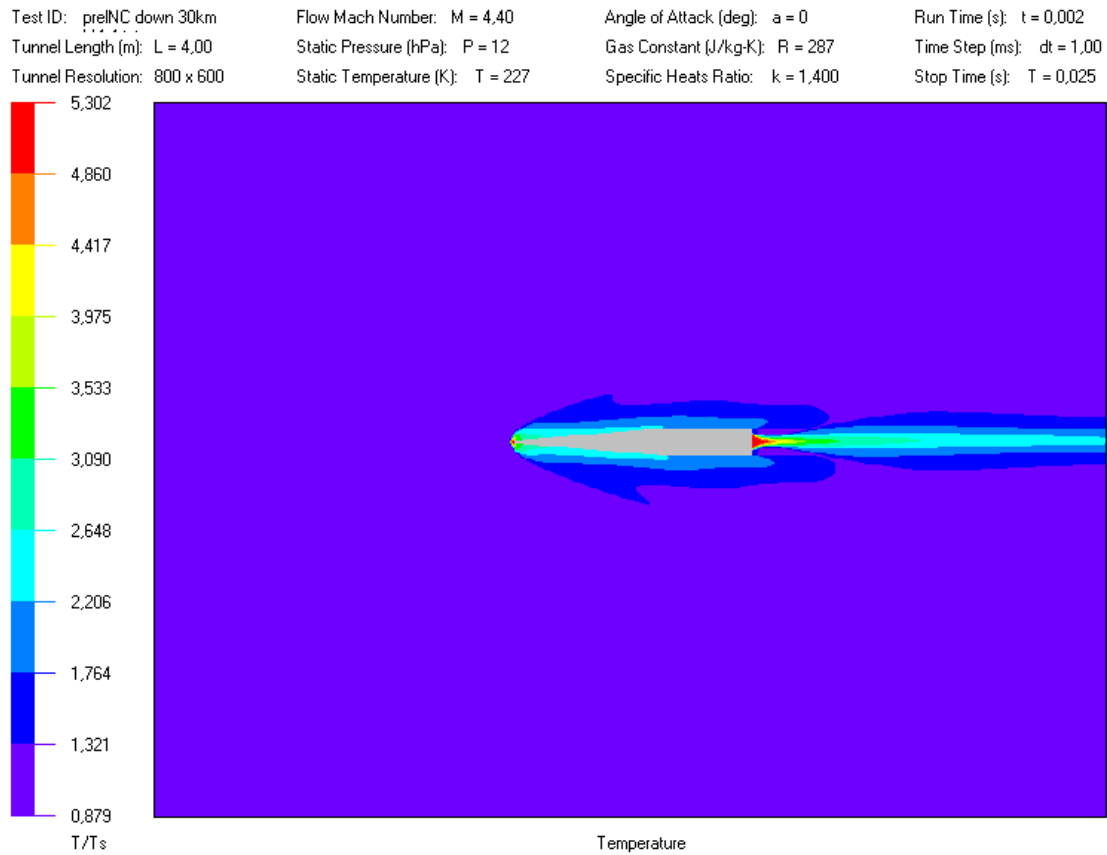

Because of limitations stated before all the next computations are performed for descending vehicle. As per Hans & Richard's data files the descending velocity at 30km above the sea level is about M4.4. The results are similar to ascending vehicle at the same altitude.

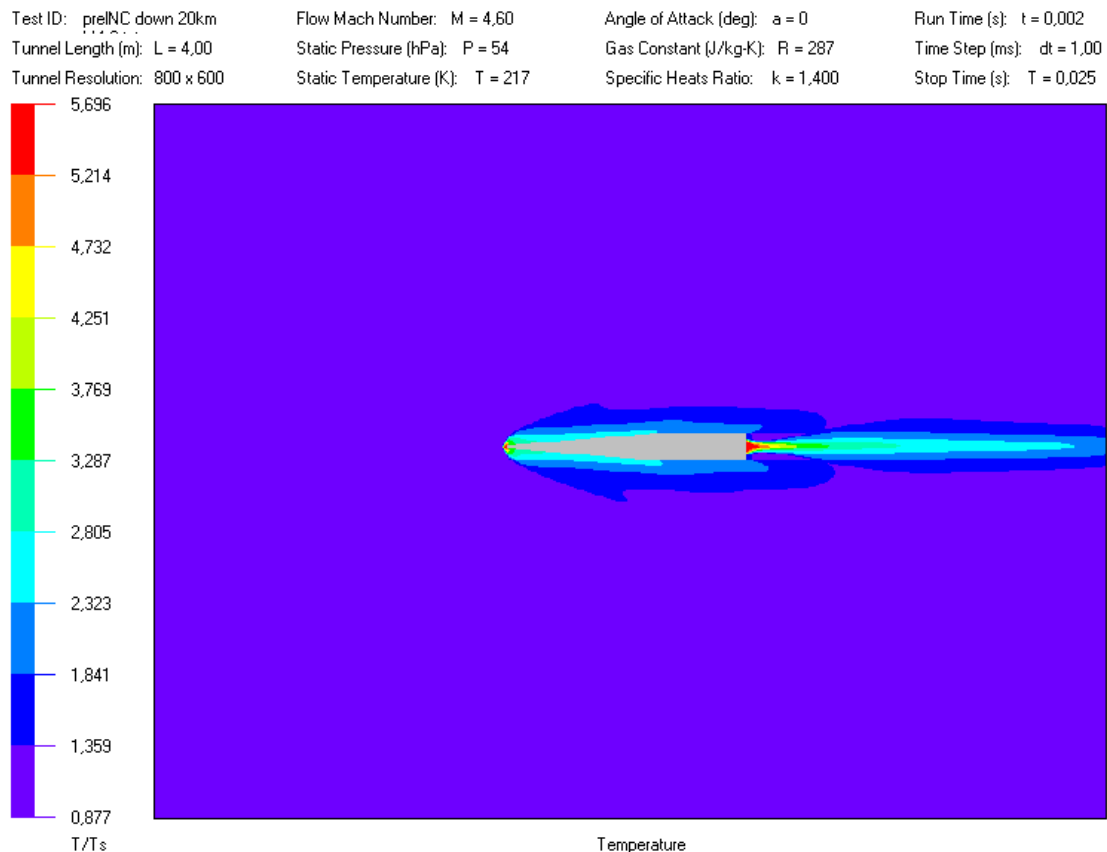

Temperature profile at 20 km & M4.6.

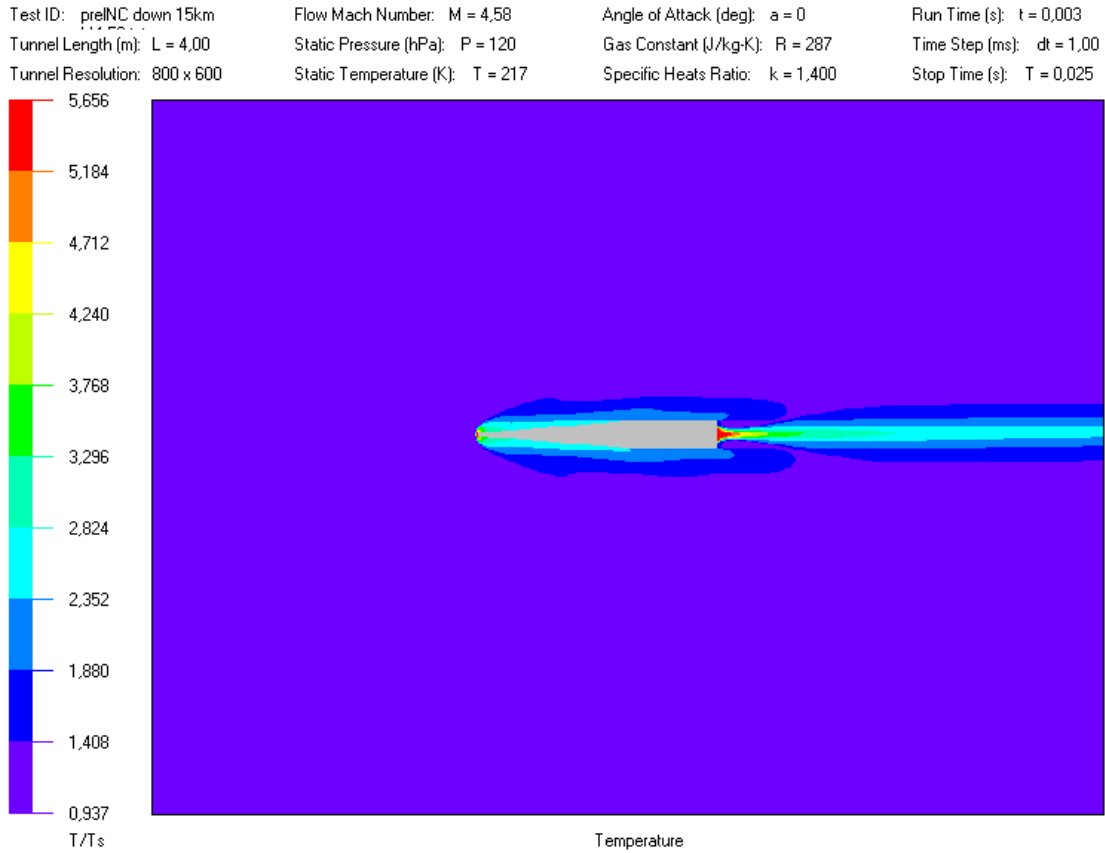

Altitude 15 km, M4.58, surface temperature is about 550 deg on the cone.

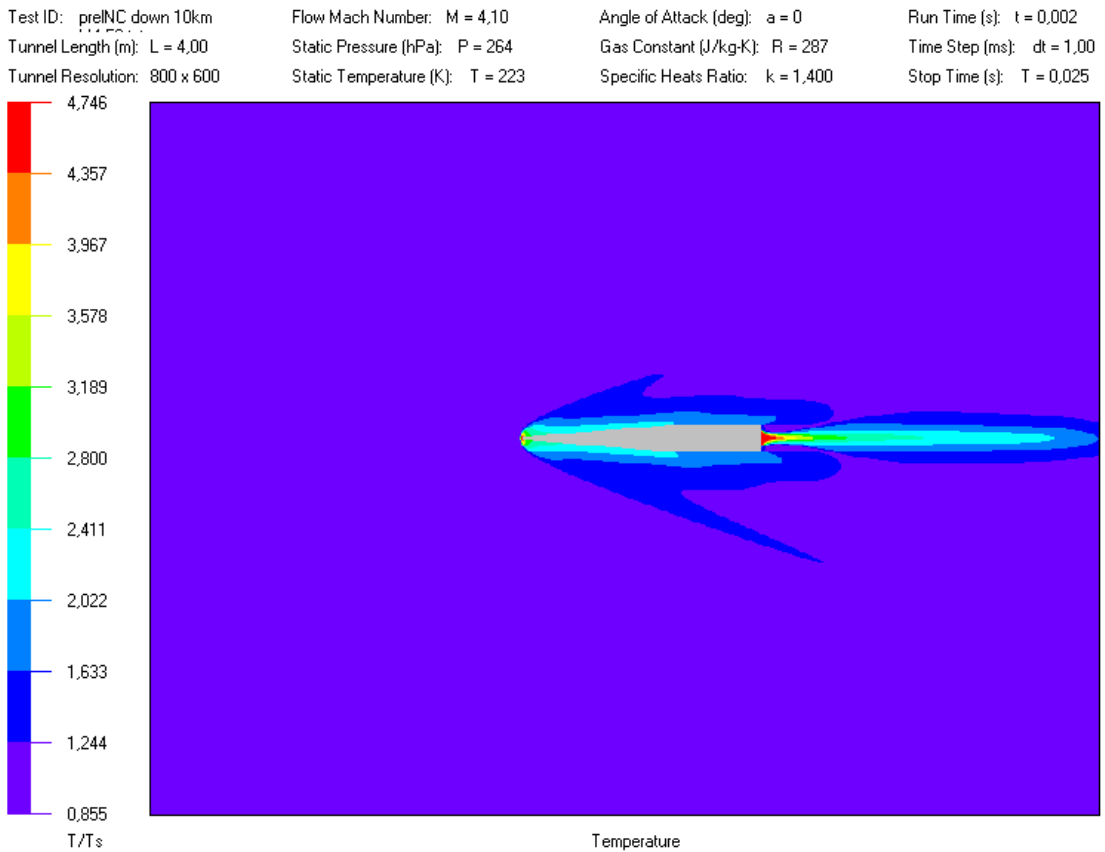

At 10 km altitude the primary chute is expected to be ejected; at this point the NC is surrounded by air heated up on temperatures between 512K and 900K; at time of chute ejecting might be

expected lose of stability, tumbling of the NC. For this reason on some points, very high temperatures might be expected. Design of the primary chute should be able to sustain these conditions. The thermal expansibility of the NC/airframe joint should be considered; the standard design might stick together.

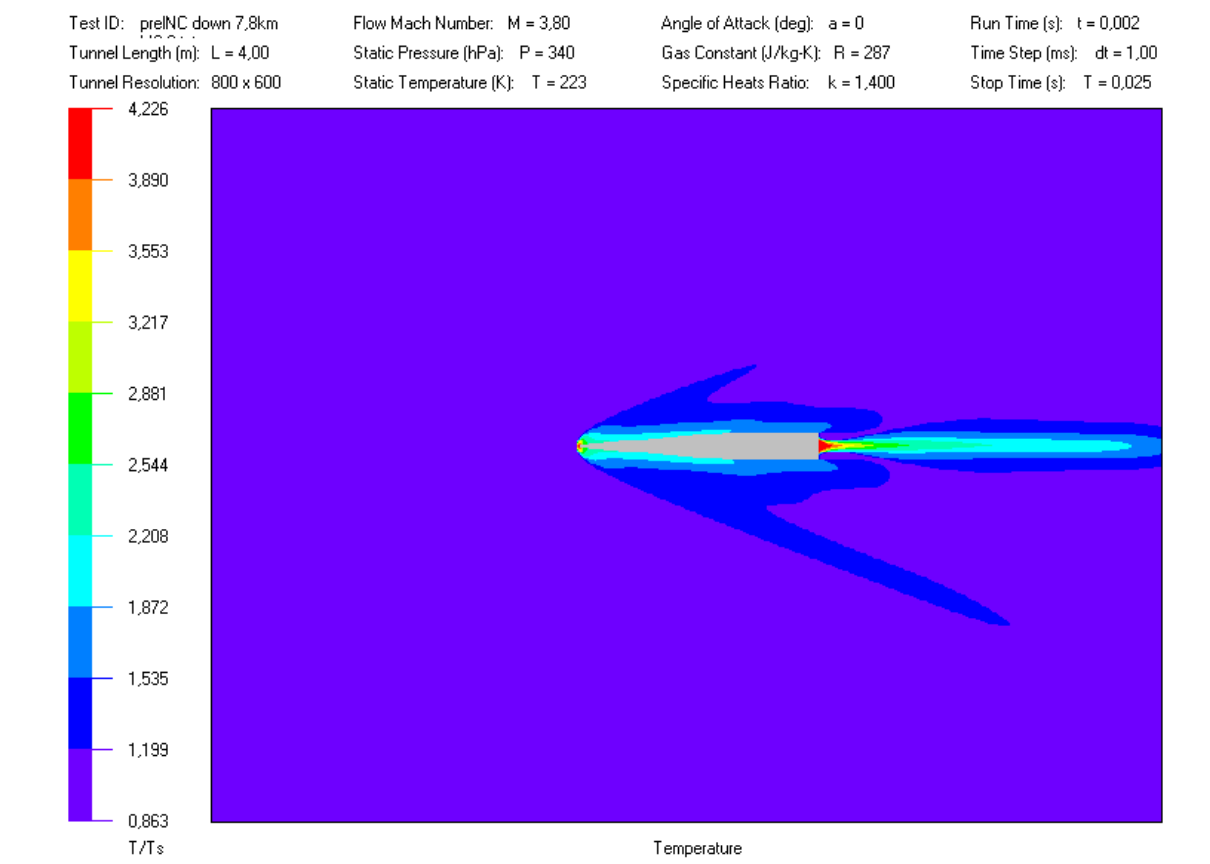

In case of chute ejection delay for 2 sec - the surface temperature slowly decreases. However, the atmospheric press increases rapidly and dynamic load during opening of the chute as well.

Note: All color pictures might be magnified for better clarity. Original profiles of the streamlines, pressure & density are accessible if requested.

Discussion: The temperature of surface layer during the flight reaches values between 500-800 degC, the thin composite skin without ablator or another thermal insulation is unable to survive these conditions. Design of the NC must consider the thermal wave and related problems as well, such as coefficients of thermal expansion of different materials. The NC round tip made from graphite should not caused any problem. In addition, evaporative cooling of the tip might be used to slowing down the thermal wave diffusing into the NC structure. Releasing of the NC joint followed by ejecting of the chute requires smooth movements of all thermally loaded parts; classic design such as concentric tubes might cause chute failure because of "sticking" moving parts together.

Another critical point is traveling in transonic velocities between 13-16 sec of the flight. Any wobbling caused by lower margin of vehicle stability might cause failure of the mission. For this reason, the vehicle stability should be considered very carefully.

Another point of consideration is aerodynamic drag caused by absence of the "tail boom" section. Elimination of this drag would lead to the better performance of the SSTS vehicle.

Notes: