



MiniSShot

Pyrotechnic Separation Device

Assembly Manual

Rev. 2010/12/20

Introduction

This document describes the procedures to assemble the *MiniSShot* Pyrotechnic Separation Device (PSD). The PSD serves as a structural airframe joint that, on command, forcibly separates the rocket into two sections in order to release the drogue parachutes. The PSD cross-sectional view is illustrated in Figure 1, with photos of the actual device in Figures 3 and 4.

All 2010-12-20 revisions to this document are indicated in blue font.

I. Assembling the Ignition Plug

1. Install Ignition Plug bridgewires, as explained in Appendix A.
2. Carefully push polyethylene charge holder cup onto Ignition Plug.
3. Fill cup with pyro charge, leaving approximately 1 mm empty space at top of cup.
4. Smear a thin skin of RTV to seal cup. Wipe any excess off sides of cup.
5. Set aside to cure for one hour minimum.

II. Loading the Gun

1. Lightly smear grease on the Piston o-ring and insert into Gun barrel. Visually align thru-hole in Piston with hole in Gun as viewed through the Ignition Plug opening.
2. Drop Firing Pin into hole through Ignition Plug opening and using Pin Gage, push in until approximately flush with near end pin barrel. Pin should slide easily. If tight, remove Firing Pin and rotate Piston 180 degrees.
3. Insert Pin Gage in far end of pin barrel until it contacts end of Firing Pin. Verify *minimum* depth is achieved. If not, use the Gage to lightly tap the Pin further in as needed.
4. Smear grease on tiny (-007) o-ring and place in receptacle in Gun. Place Cap over o-ring. Align such that stamped "1" is visible and toward the Ignition Plug. Retain with two #40 SHC screws.
5. Insert Stop Pin through cap and o-ring and fully tighten using screwdriver to snug up firmly.
- | |
|--|
| Note: For MS flight only, apply a drop of Loctite to threads |
|--|
6. Smear a tiny amount of silicone grease on the Ignition Plug o-ring, then screw Plug into the gun (using a 9/16" wrench if required) all the way but do not snug up.

III. Assembling the PSD

1. Position PSD Mechanism onto Aft Taper Coupling, aligning holes with the pins of the Mechanism, reference Fig.1 (note: any hole may be aligned to any pin).
2. Place **three** spacers (washers) between coupler and Mechanism Plunger and secure with masking tape.
3. Place the assembly flat on a table. Carefully align the pins and holes. Press forcibly down on Lug until the pins begin to extend outward into the coupler holes. To fully engage the pins in the holes, flip the assembly over and tap the Lug against a table top.
4. Remove the spacers, taking care to keep the pins extended.
5. Next, carefully push the pins inward until all are **approximately** flush with the coupler surface. To facilitate this, lift up the assembly and gently press in the mechanism arms.
6. **Take the Forward Taper Coupler and place over the tapered portion of the Aft Coupler.** Grip the assembly in both hands and squeeze tightly together.
7. In order to extend the pins outward and to fully engage the holes of the forward coupler, flip the assembly over and forcibly tap the Lug on a tabletop. **The pin ends should be *approximately* flush with the surface of the Forward Taper Coupler.**
8. **As shown in Fig.2, use pliers (or screwdriver) to gently press & extend each pin outward. Pin ends need not be fully flush.**

IV. Installing Gun in the PSD assembly

1. Screw the threaded portion of the Piston into the cruciform fitting of the mechanism. It should be fully screwed in such that no threads are visible, **but do not tighten.**
- | |
|--|
| Note: For MS flight only, apply a drop of Loctite to threads |
|--|
2. Slip the two Gun attachment brackets over each end of the Gun, **one at a time.** The slotted bracket fits the Ignition Plug end. Align the “S” marking on the coupler to the slotted bracket, and the “H” marking to the holed bracket. **Back off the Gun as needed to make this alignment (1/2 to 1 1/2 turns).** The orange wires should be aligned to the opening in the slot. If not, back off the Ignition Plug slightly as required. *Note - the Ignition Plug need not be tightened to seal effectively.*
3. Mount each bracket with two #40 flat head cap screws. Do this by slightly screwing in one fastener, then install the other, before tightening both fully.

V. Attaching the Anti-Rotation tether

- 1. Insert a #40 SHC screw through the Tether Retainer, then through the looped end of the tether.
- 2. Screw into the No.4 pin guide of the mechanism, and gently snug up (see Fig.3).
- 3. Install the second retaining screw.

VI. Checks

- 1. Use to Pin Gage to verify the Firing Pin is in correct position in the Gun. If the Firing Pin is not to the minimum depth, use a tool to lightly tap on the Pin Gage to achieve minimum depth.
- 2. Verify the Stop Pin is tightened snugly.

Refurbishment

Remove and disassemble the Gun fully. Clean with hot water & soap. Use a Q-tip to clean the bores of the Gun. O-rings *need not be removed* or replaced unless visibly damaged. Dislodge the Stop Pin by tapping the threaded end of the Piston, then unscrew to remove. Remove the Firing Pin by tapping with a punch through the opening in the barrel.

Clean the mechanism with hot water and a toothbrush. Dry thoroughly with a hair dryer. Re-lubricate sliding pins with EP grease.

Appendix A - Bridgewire installation

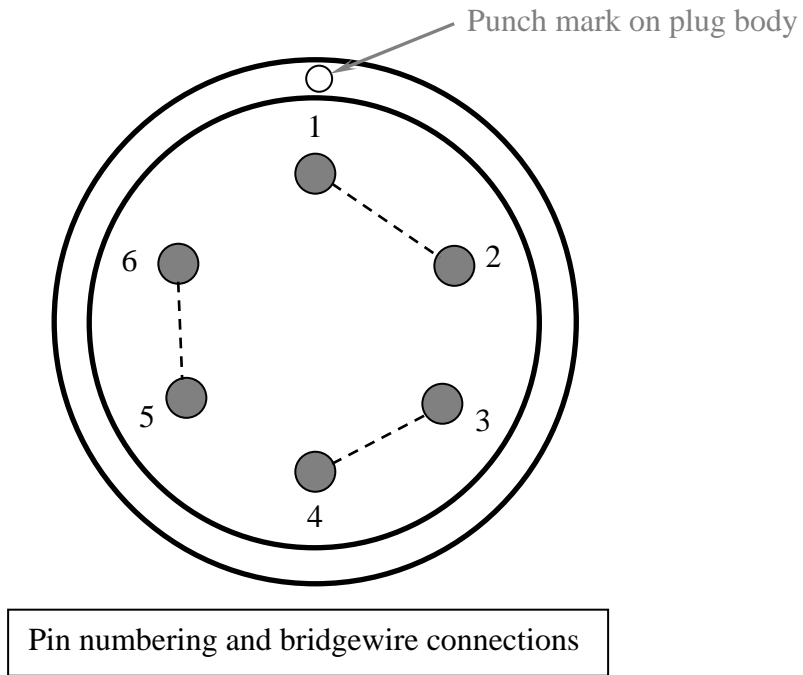

Installing Bridgewires

Cut a piece of nichrome wire approx. 1" long. Using a suitable magnifier (e.g. 10x loupe), insert one end of wire into eye of pin 1, threading pins from inside toward outside:

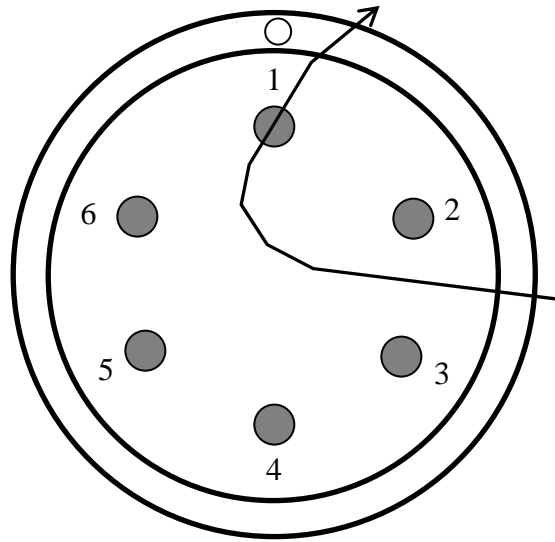

Threading nichrome , step 1

Next thread other end of nichrome through pin 2, as illustrated:

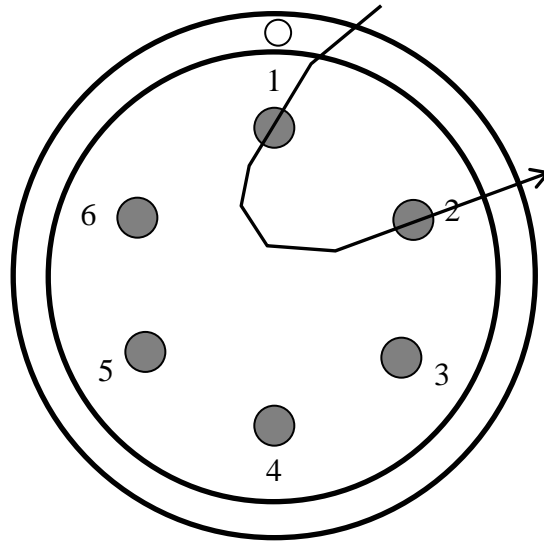

Threading nichrome, step 2

Gently pull each end of wire to remove slack, ending up with an arching bridgewire as illustrated:

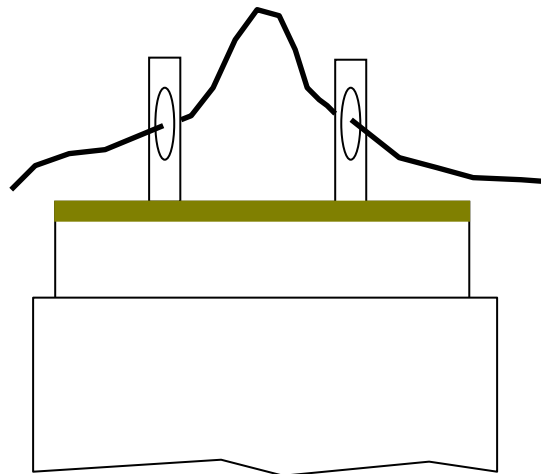

Solder nichrome to pins. Use of acid flux is very helpful. Clean off flux with alcohol if needed in order to examine joint using 10x or 20x magnifier. Ensure nichrome is immersed in solder.

Checks

- 1. Using a toothpick lightly tug on bridgewire to ensure solder bond has been achieved.
- 2. Check resistance of each bridgewire - should be approximately 5 ohms (net).

Refurbishment

Generally, the two non-fired bridgewires survive intact. Wash off burnt residue with hot water taking care not to disturb the two intact bridgewires.

To replace burnt-out bridgewires, use tweezers to remove the wire remains after heating pin with solder gun. To clear the eye of solder, a strong blast of air (breath) seems to work effectively, after melting with solder gun. Alternatively, use of copper braid desolder-wick works well. A vacuum plunger is another possible solution but does not seem to work as well as the other two means.

http://en.wikipedia.org/wiki/Solder_wick

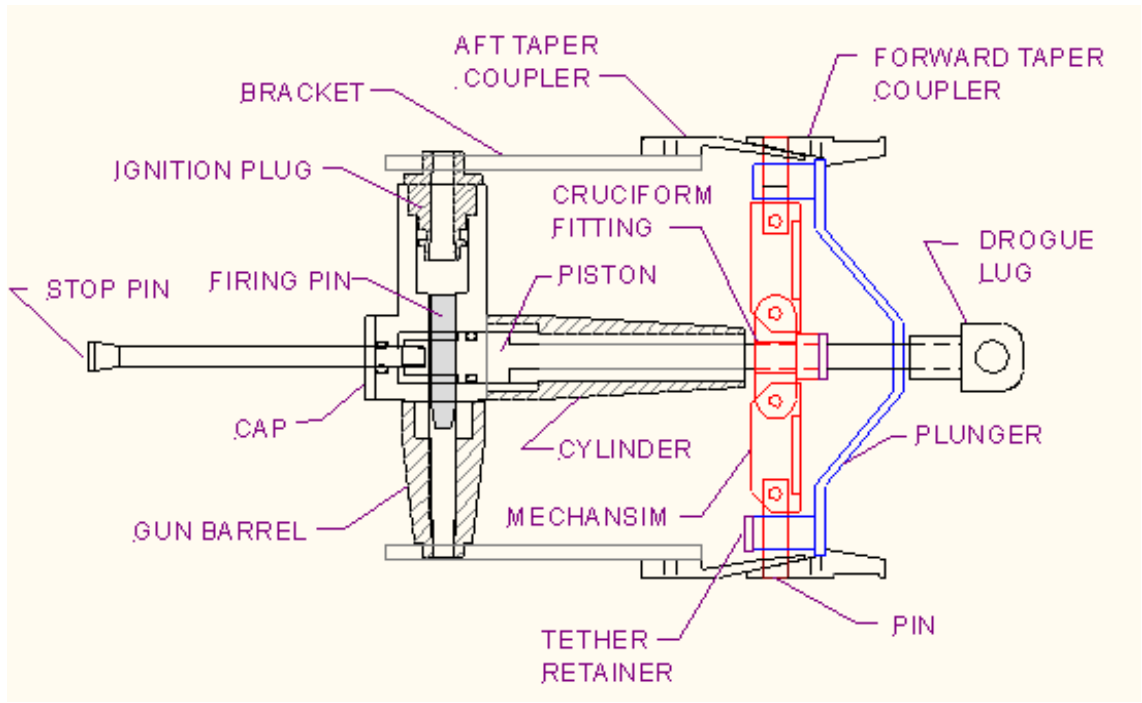

Figure 1 - Cross-sectional view of PSD design



Figure 2 - Using pliers to extend pins fully outward

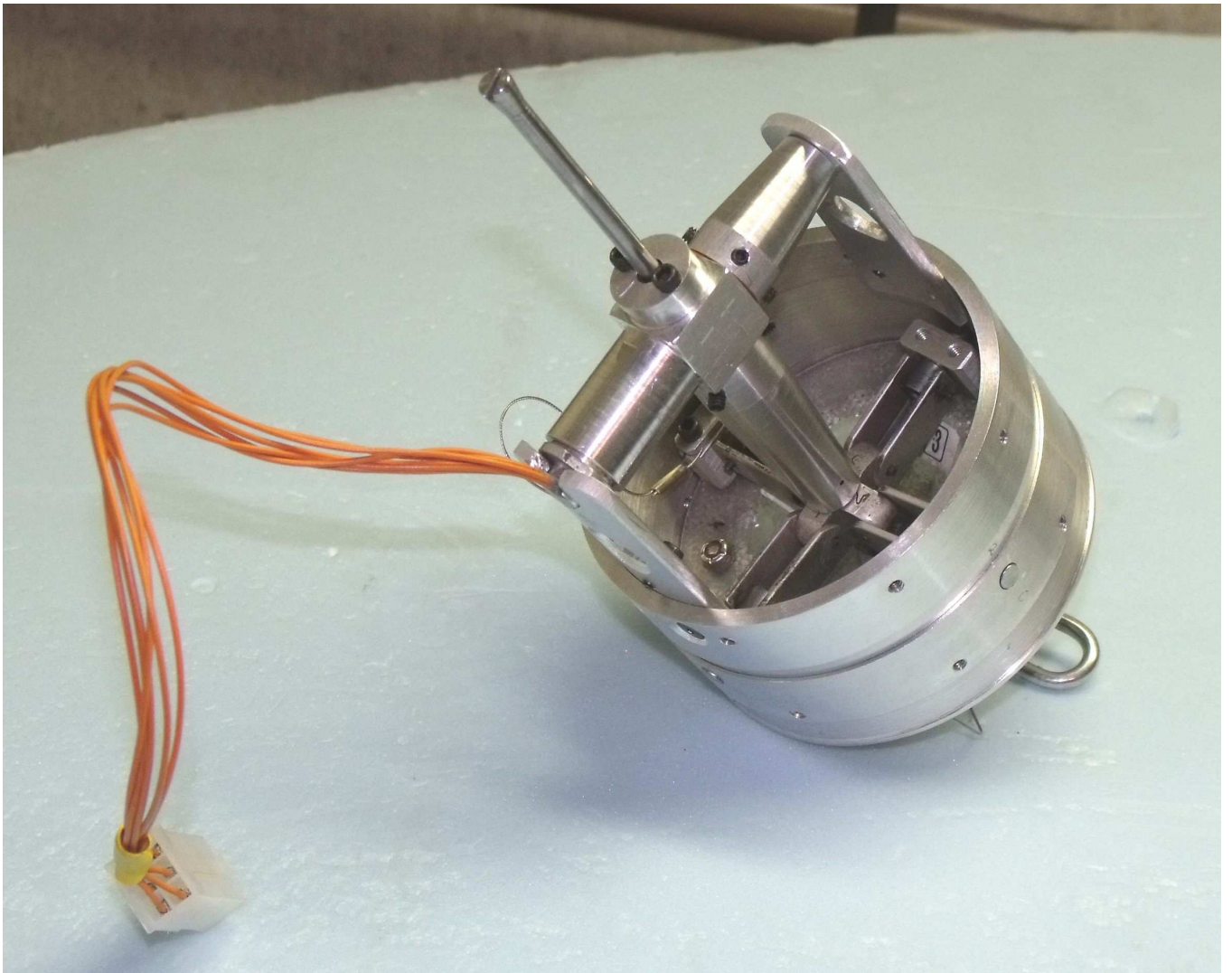

Figure 3 - Photo of assembled PSD

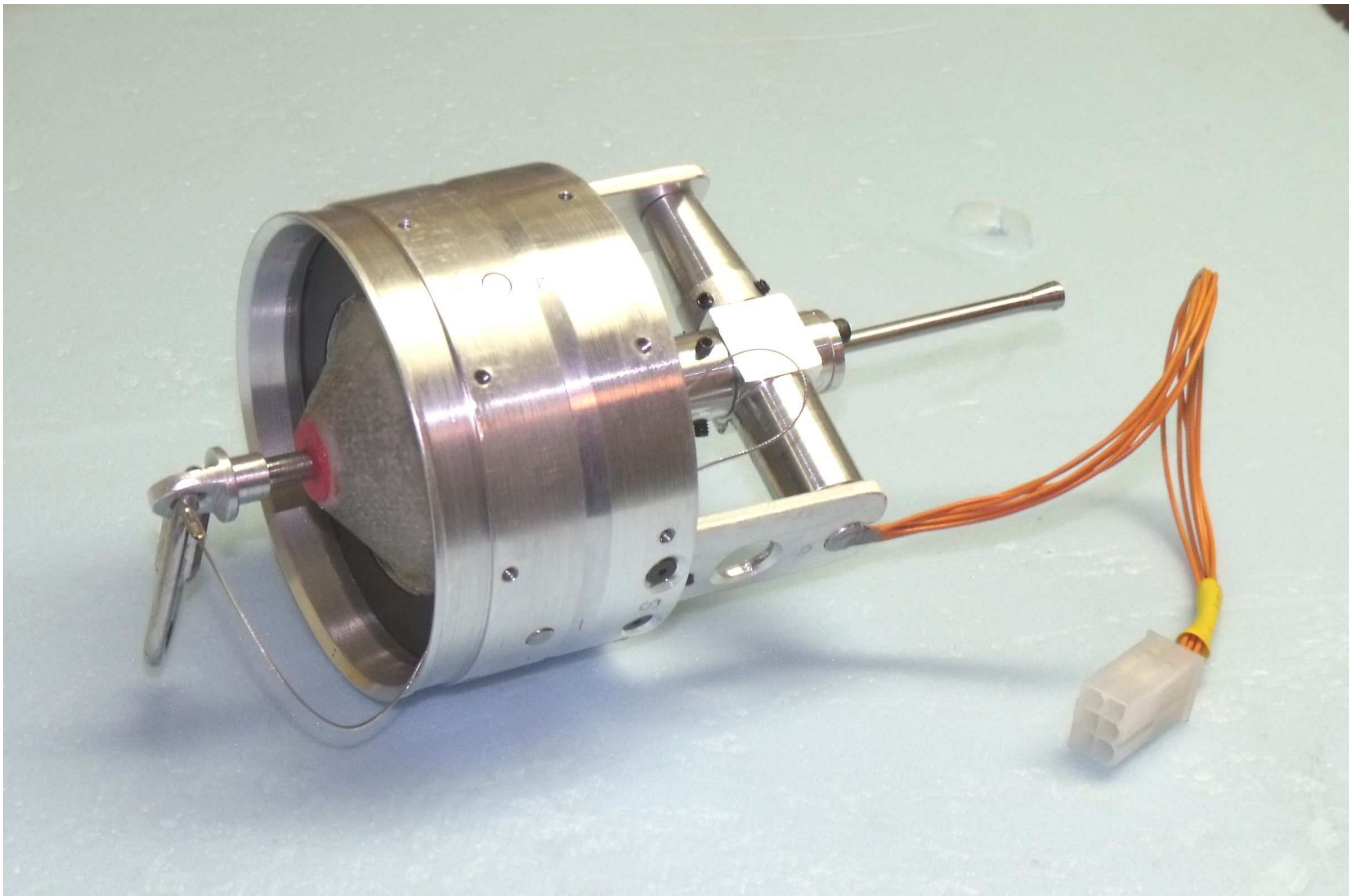

Figure 4 - Photo of assembled PSD