



MiniSShot

ProtoSShot-M Mark II

and

ProtoSShot-M Short Stack

Propellant Casting Guide

Rev.2008/08/01

General information

This document is intended to serve as a guide for casting propellant for the *ProtoSShot-M Mark II* and *ProtoSShot-M Short Stack* rocket motors.

Pre-casting setup & tasks

1. a) *ProtoSShot-M Mark II*:
Paint 2 coats of intumescent paint on interior of each casting tube.
Leave bare ½” from both top and bottom ends.
Allow drying between coats.
Allow several hours drying before casting propellant.

- b) *ProtoSShot-M Short Stack*
Paint 2 coats of intumescent paint on interior of one casting tube, 1 coat on second casting tube, and leave third casting tube paint-free.
Leave bare ½” from both top and bottom ends.
Allow drying between coats.
Allow several hours drying before casting propellant.

2. Accurately weigh all casting tubes individually and record, or mark weight on the casting tubes.
3. Apply shrink tape around top end of casting tube.
4. Prepare coring rods by applying a light coat of PVA, allow to dry completely, then apply light coat of Mann 400.
5. Prepare casting apparatus for propellant loading, and mount onto vibrating table as shown in Figure 1.
6. Make certain band clamp has been tightened.

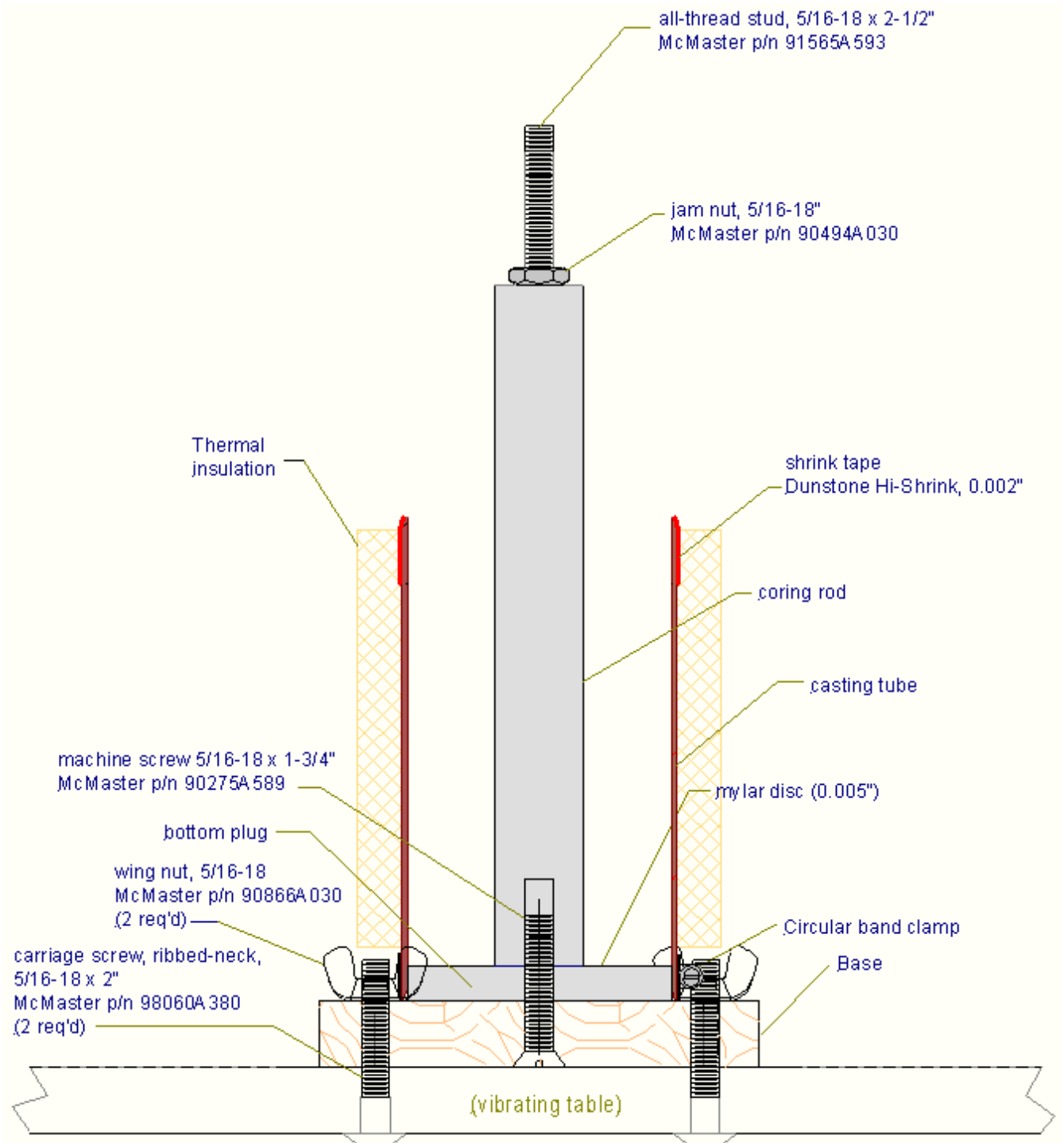

Figure 1 – Setup for propellant loading operation.

Propellant casting preparations and procedure

7. Use only thermostatically controlled heating vessel(s). Preheat vessel to temperature range of 250°F (120°C) to 295°F (145°C).
Do not allow temperature of propellant to exceed 300°F (150°C) for extended duration.
8. Weigh out enough powdered mixture for one or more segments (Table 1) and add to heating vessel a little at a time. Allow melted slurry to reach desired casting temperature 265°F (130°C) to 285°F (140°C).
9. Power up the vibrating table.
10. Pour & scoop slurry, with use of the spatula, into casting mould. Fill level to the top of the casting tube.
11. Allow vibrating table to run for a minimum duration of two minutes before powering off.
12. Remove casting setup from vibrating table by undoing two wing nuts.
13. Slip mylar disc into place over coring rod and onto surface of propellant.
14. Slide Top Cap into place over coring rod and press down gently, allowing Top Cap to seat on top of propellant surface.
15. As is shown in Figure 2, place steel shim, spring and spacer over coring rod. Loosely install washer and wing nut.

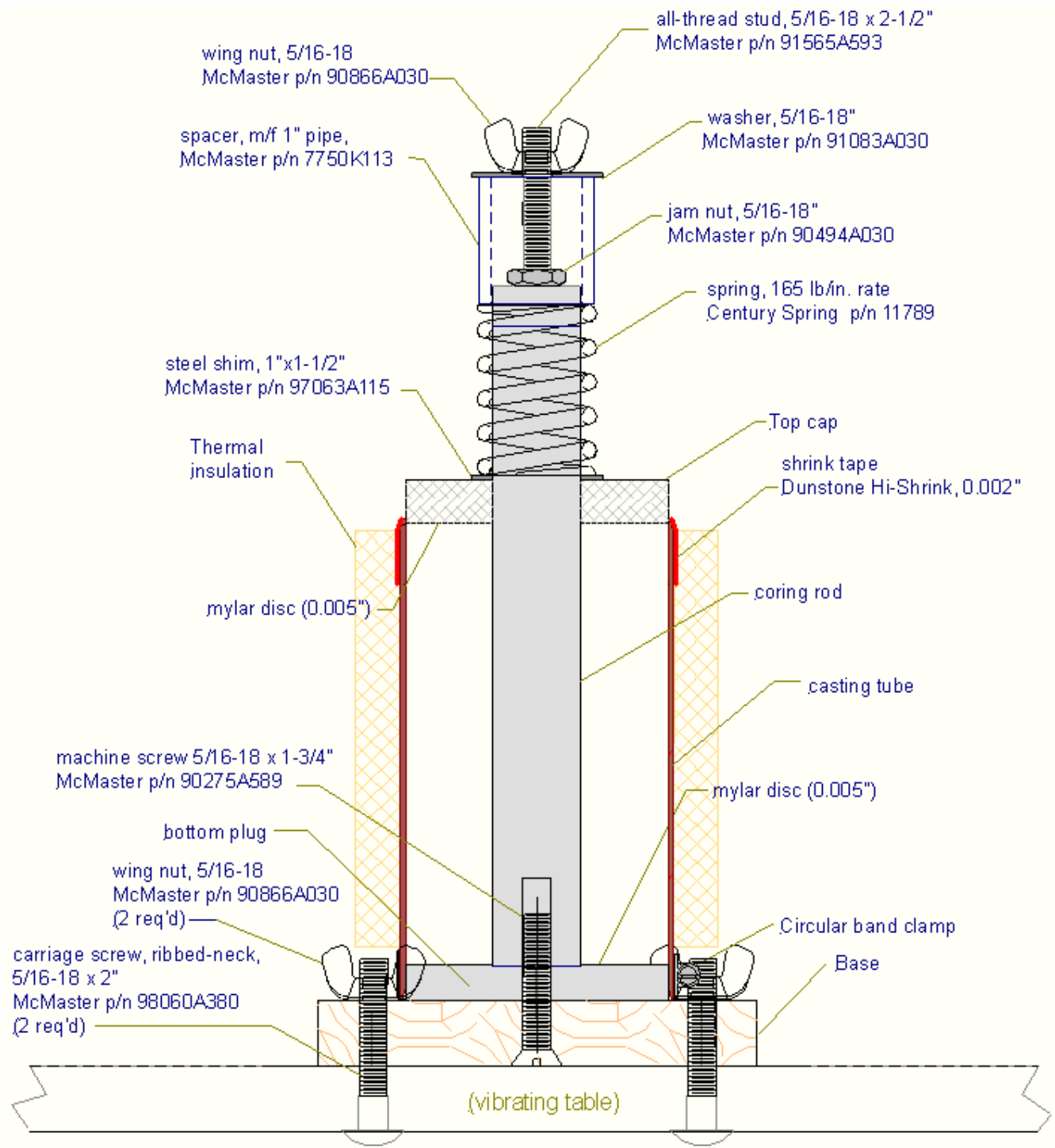

Figure 2 – Casting mould arrangement.

16. Gently tighten wing nut to remove slack.
Top Cap should be slightly submerged into casting tube (approximately 1/16”).
17. Allow to cool approximately one hour, then gently tighten wing nut to maintain mild pressure (propellant shrinks as it cools).
18. Remove thermal insulation sleeve.
19. Allow cooling to near-ambient temperature (outside of casting tube should feel only slightly warm). This will take several hours.
20. Remove (or loosen) band clamp.
21. Tighten wing nut until spring is fully compressed.
DO NOT EXCEED 10 HOURS FROM TIME OF CASTING before doing this step.

Disassembly and post-casting procedures.

22. Allow propellant to fully harden prior to releasing spring pressure (minimum 24 hours from time of casting).
23. Disassemble casting setup. Bottom Plug may be removed by use of the Plug Removal Tool fastened to the Bottom Plug with a 5/16" machine screw. Use mallet to gently tap on top end of Plug Removal tool.
24. Remove shrink tape from casting tube.
25. Weigh each grain segment and record individual weights.
Measure and record depths of each recessed end, and casting tube lengths, as shown in Figure 3.
26. Store finished grains in sealed containers or poly bags, in a secure location or locations.
27. All segments to be primed at both ends (core excluded) with "ignition primer". Ignition primer consists of a well-blended mixture of potassium nitrate and charcoal (80/20 ratio, by mass). A slurry of the powdered mixture and 70% isopropyl alcohol prepared to a consistency of thick paint is painted on to a thickness of approximately 0.010" (0.25 mm).

IMPORTANT NOTE: The scope of this document does not include complete information on safety precautions that must be followed. Refer to other sources for such information. Recommended safety wear, as a minimum, are protective glasses, clear faceshield, leather gloves, and leather or heavy jacket (long sleeves).

	Basic formula KNSB	Amount per segment *
KN	65%	635 grams
Sorbitol	35%	342 grams
	100%	977 grams
* includes 70 grams for wastage		

Table 1 – Propellant formulas and constituent masses required per segment.

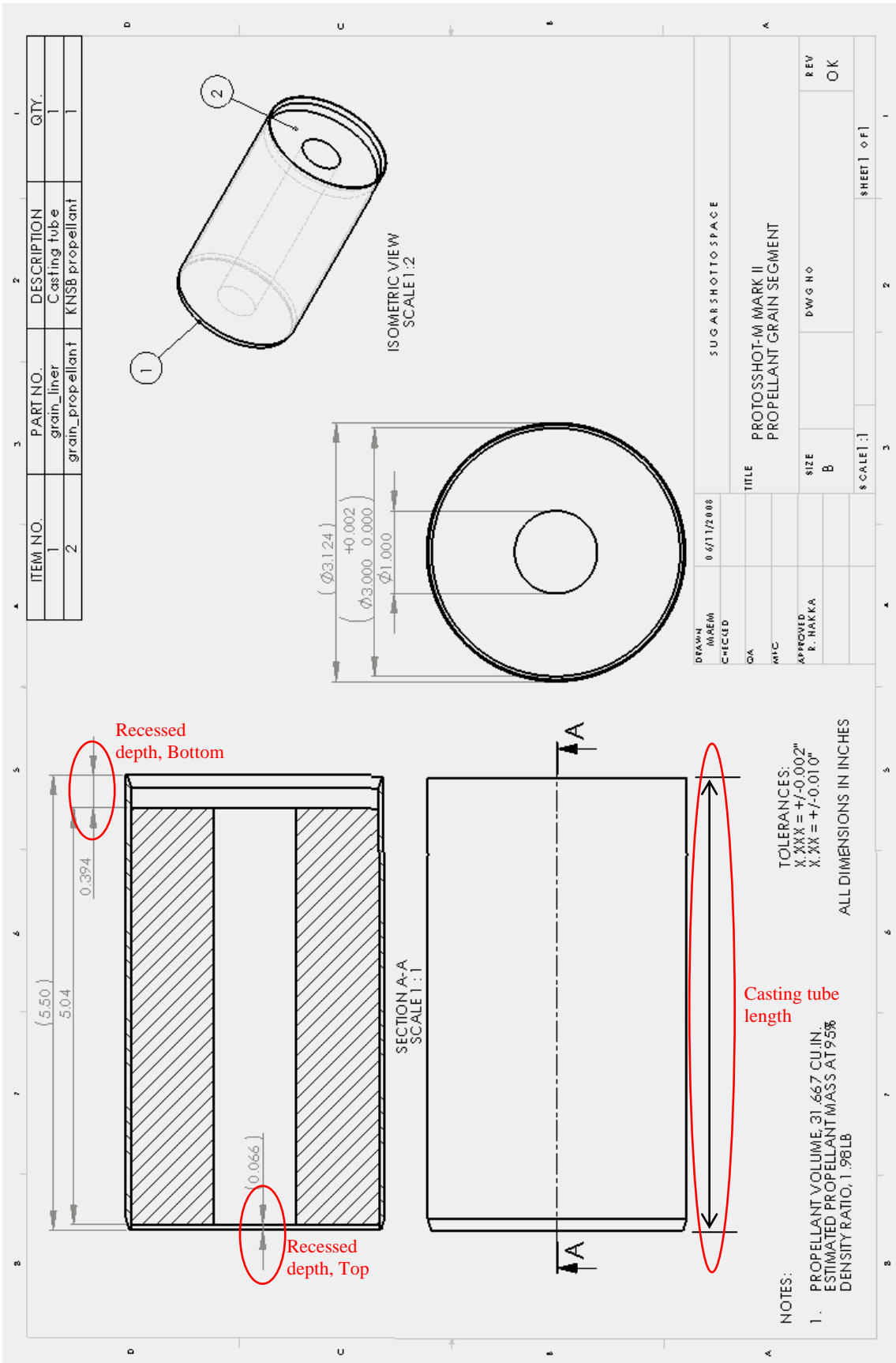

Figure 3 – Drawing of propellant grain segment, indicating measurements to be recorded.